

1 2 3 4 5 6 7 8

A
B
C
D
E
F

A
B
C
D
E
F

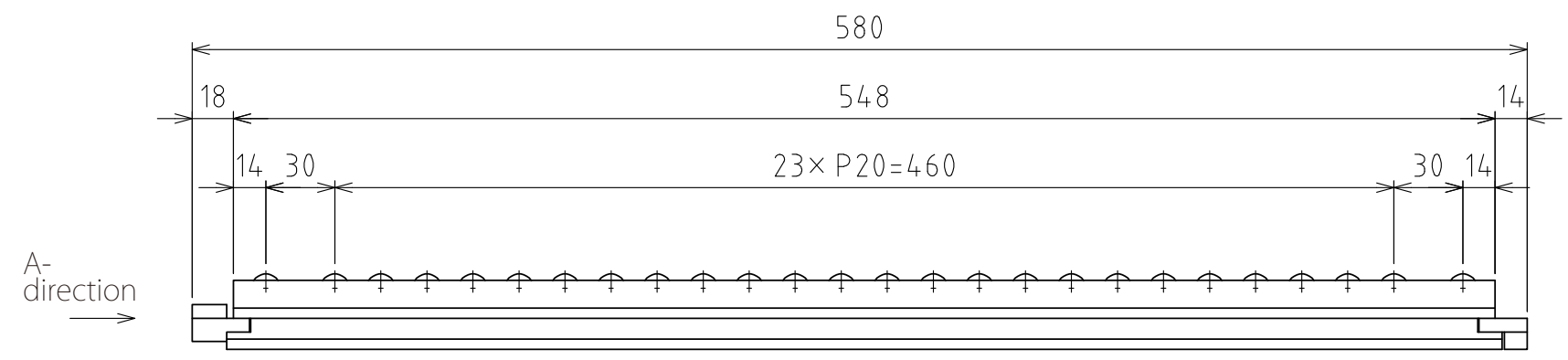
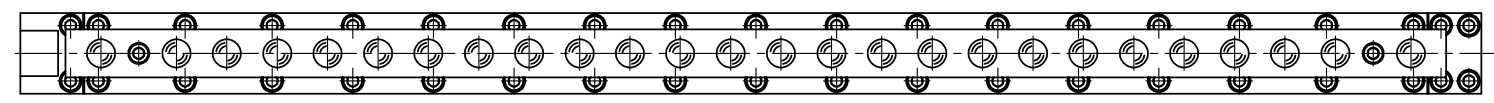

A-direction
→

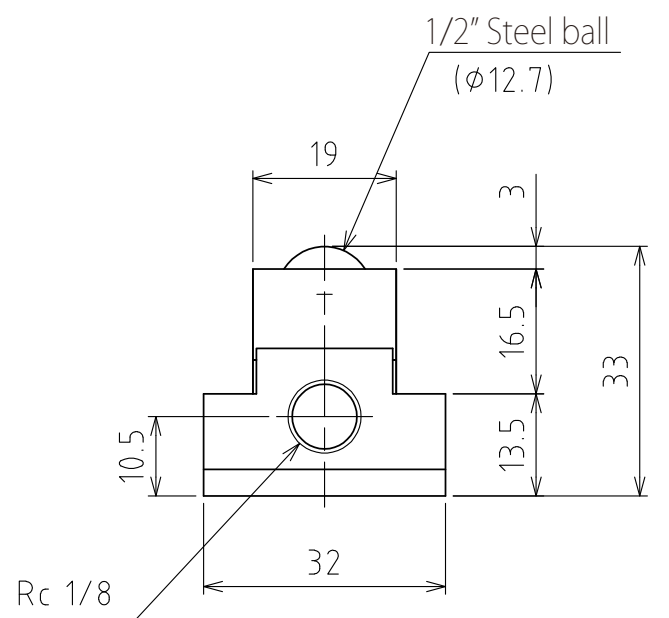

View A

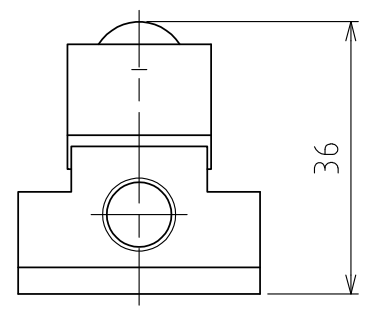

Rising
(stroke 3mm)

(Scale 1:1)

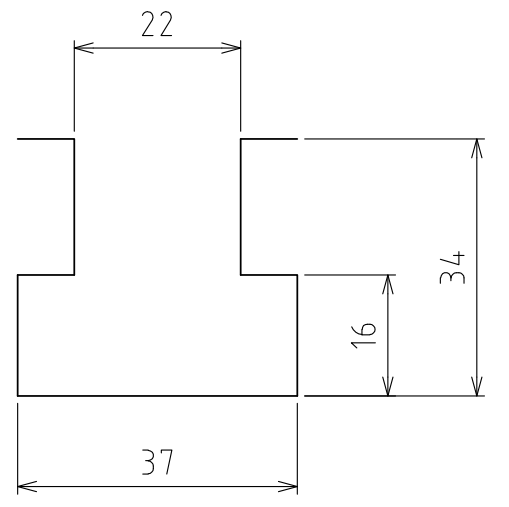

T-groove size

spec

Series	AFU-1932 series	
Material	Ball	SUJ2
	Ball seat	SCM415
	Body	Steel
Means to lower the balls	Spring return system (lowers by exhausting)	
Weight	2.6kg	

Capacity	Air pressure [MPa(kgf/cm ²)]	Load capacity (Unit) [kN(kgf)]
	0.3 (3.1)	1.96(199.9)
0.4 (4.1)	2.36(240.7)	
0.5 (5.1)	3.14(320.2)	
0.6 (6.1)	3.92(399.7)	

設計 DESIGNED BY	古内	2021/07/26	名称 TITLE
製図 DRAWN BY	古内	2021/07/26	
検図 CHECKED BY	技術部 坂根	21.11.29	AFU-1932-580
承認 APPROVED BY	技術部 花村	21.11.30	
尺度 SCALE	1:3	サイズ SIZE	A3
第三角法			
			図面番号 DRAWING NO. SAU04002-F03
			変更回数 REV.MARK

1 2 3 4 5 6 7 8