

1 2 3 4 5 6 7 8

A  
B  
C  
D  
E  
F

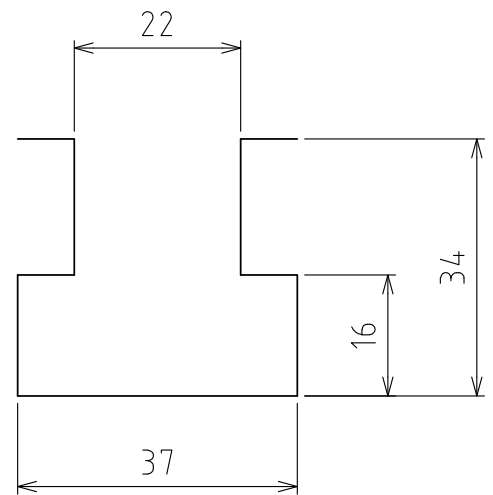
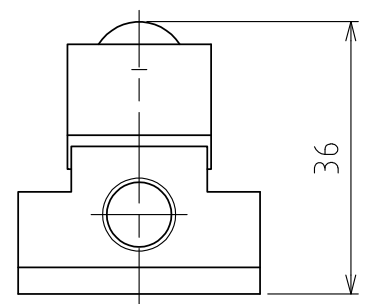
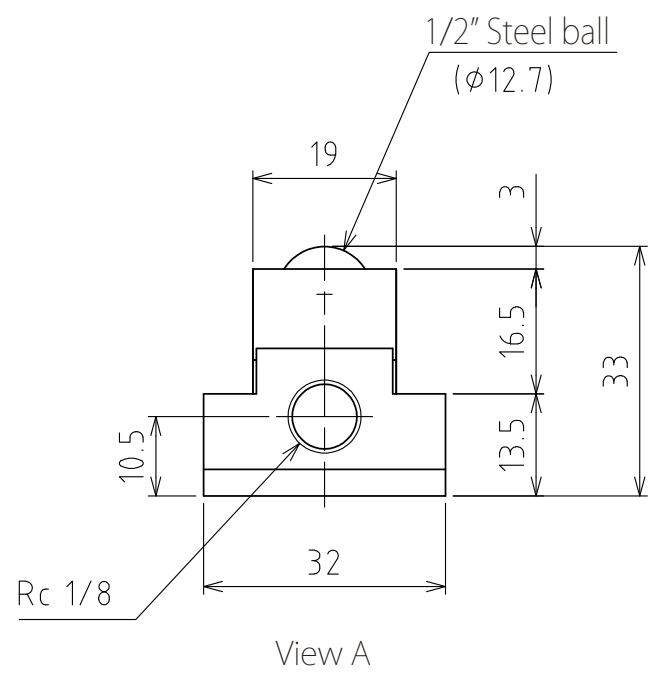
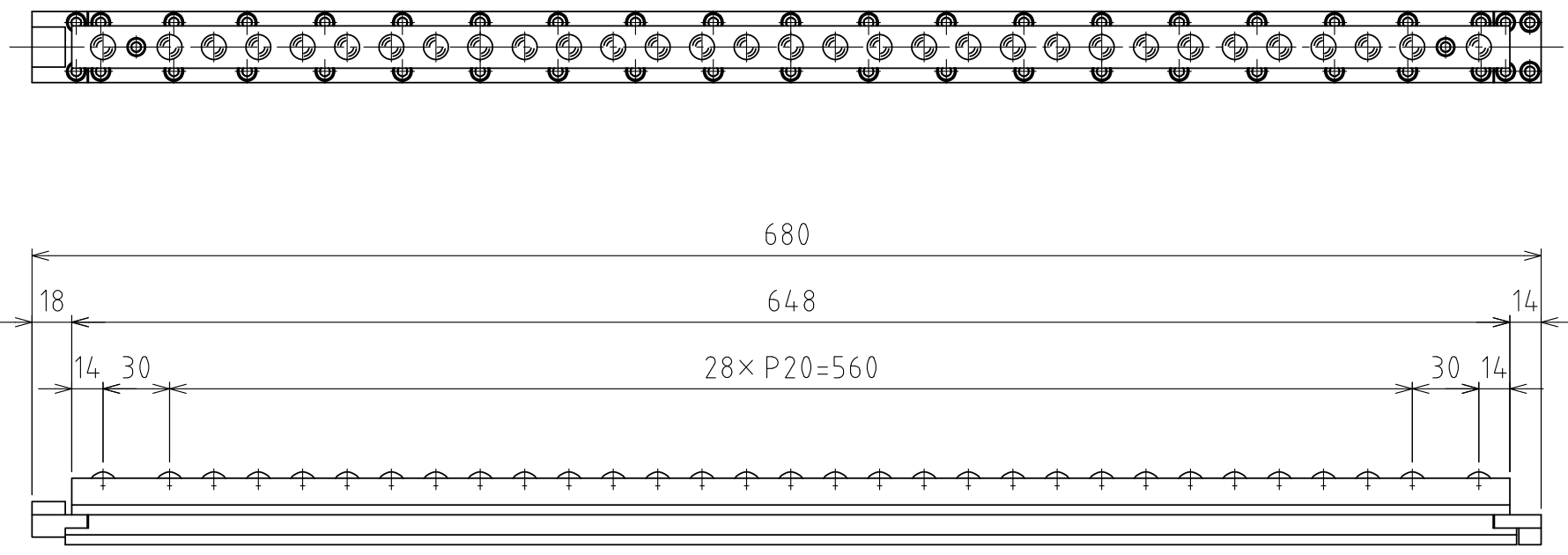

(Scale 1:1)

spec

Series	AFU-1932 series	
Material	Ball	SUJ2
	Ball seat	SCM415
	Body	Steel
Means to lower the balls	Spring return system (lowers by exhausting)	
Weight	3.1kg	

Capacity	Air pressure [MPa(kgf/cm <sup>2</sup> )]	Load capacity (Unit) [kN(kgf)]
	0.3 (3.1)	2.21(224.9)
	0.4 (4.1)	2.65(270.2)
	0.5 (5.1)	3.53(360.0)
	0.6 (6.1)	4.41(449.7)

設計 DESIGNED BY	古内	2021/07/26	名称 TITLE
製図 DRAWN BY	古内	2021/07/26	
検図 CHECKED BY	坂根	21.11.29	AFU-1932-680
承認 APPROVED BY	花村	21.11.30	
尺度 SCALE	1:3	サイズ SIZE	A3
第三角法			
			図面番号 DRAWING NO. SAU04054-F03
			変更回数 REV.MARK

1 2 3 4 5 6 7 8