

A-direction  
→

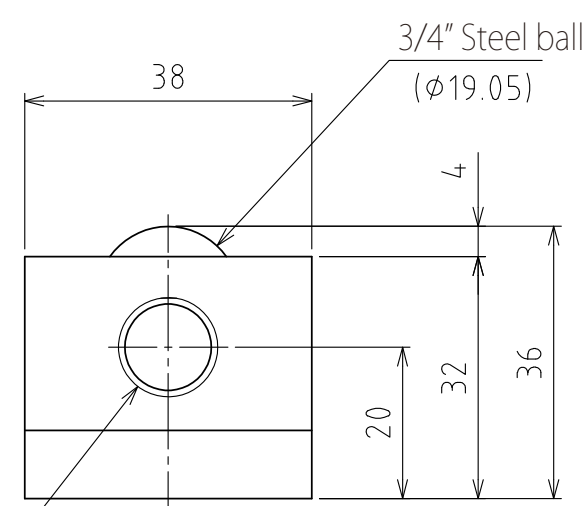

View A

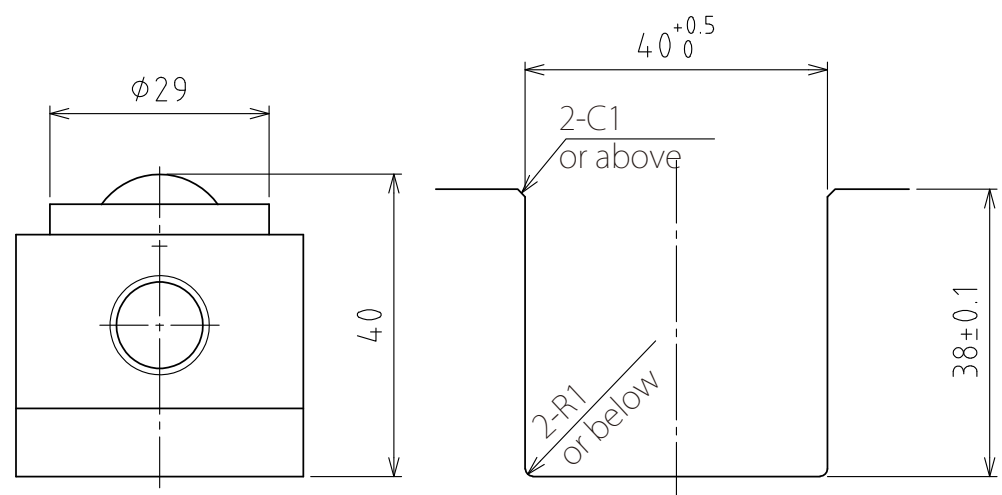

Rising  
(stroke 4mm)

Recommended groove dimensions

(Scale 1:1)

spec

Series	AFU-3836 series	
Freebear	17pcs	
Material	Ball	SUJ2
	Ball seat	SCM415
	Body	Steel
Weight	7.7kg	

Capacity	Air pressure [ MPa(kgf/cm <sup>2</sup> ) ]	Load capacity (Unit) [ kN(kgf) ]	Load capacity (One freebear) [ kN(kgf) ]
	0.3 (3.1)	3.32(338.1)	0.20(19.9)
0.4 (4.1)	4.08(416.0)	0.24(24.5)	
0.5 (5.1)	5.27(537.4)	0.31(31.6)	
0.6 (6.1)	6.63(676.1)	0.39(39.8)	

設計 DESIGNED BY	古内	2021/07/28	名称 TITLE	Pneumatically Actuated freebear unit
製図 DRAWN BY	古内	2021/07/28		
検図 CHECKED BY	技術部 坂根	承認 APPROVED BY	技術部 花村	AFU-3836-17
尺度 SCALE	1:3	サイズ SIZE	A3	
第三角法			図面番号 DRAWING NO. SAU06512-F03	
			変更回数 REV.MARK	