

1 2 3 4 5 6 7 8

A
B
C
D
E
F

A
B
C
D
E
F

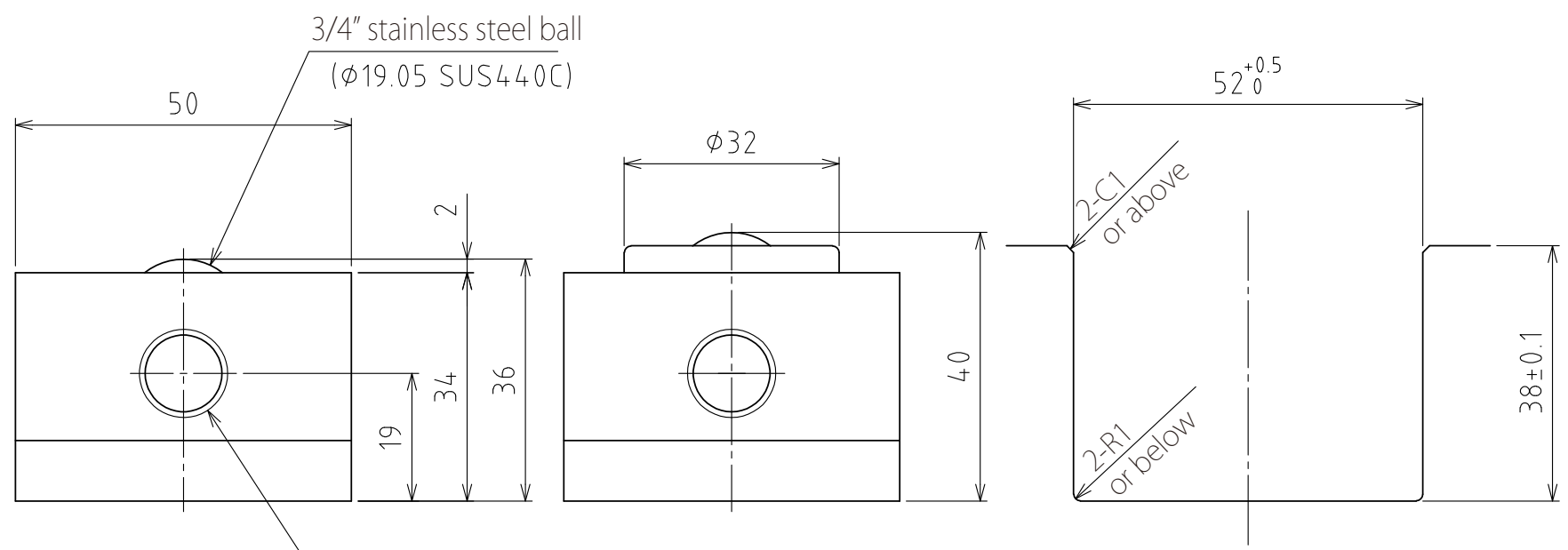
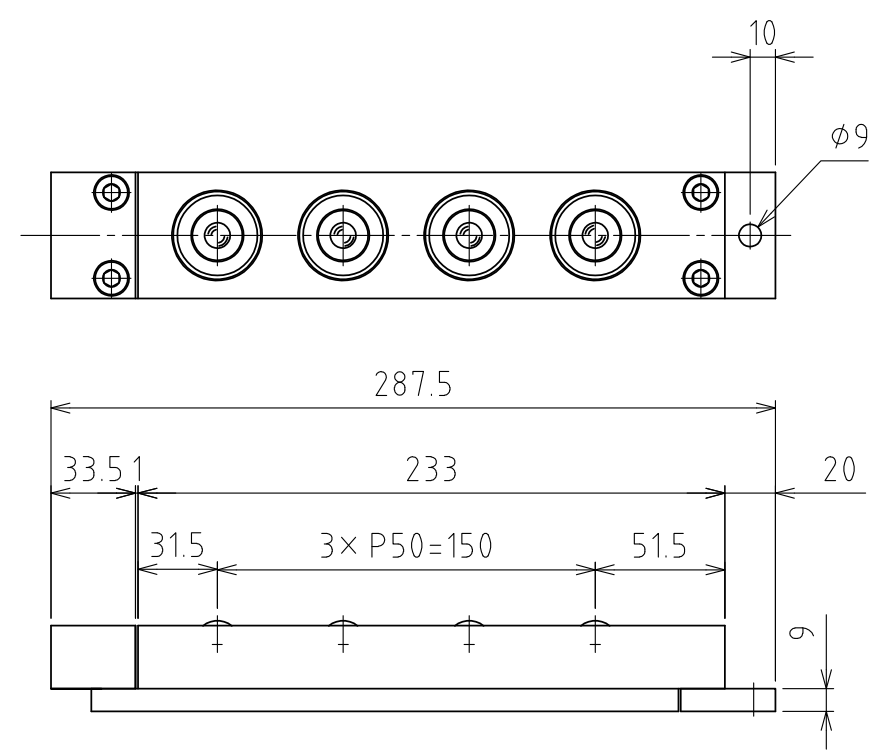

View A

Rising (stroke 4mm)

Recommended groove dimensions

(Scale 1:1)

spec

Series	AFU-5036M series	
Freebear	4pcs	
Material	Ball	SUS440C
	Ball seat	SUS440C
	Body	Steel (Electroless nickel-plating)
Weight	3kg	

Capacity	Air pressure [MPa(kgf/cm ²)]	Load capacity (Unit) [kN(kgf)]	Load capacity (One freebear) [kN(kgf)]
	0.3 (3.1)	0.78(79.6)	0.20(19.9)
	0.4 (4.1)	0.96(97.9)	0.24(24.5)
	0.5 (5.1)	1.24(126.4)	0.31(31.6)
	0.6 (6.1)	1.56(159.1)	0.39(39.8)

設計 DESIGNED BY	古内	2021/07/28	名称 TITLE
製図 DRAWN BY	古内	2021/07/28	
検図 CHECKED BY	技術部 坂根	承認 APPROVED BY	技術部 花村
尺度 SCALE	1:3	サイズ SIZE	A3
第三角法			AFU-5036M-4
			図面番号 DRAWING NO. SD-01285-F01
			変更回数 REV.MARK

1 2 3 4 5 6 7 8