

1 2 3 4 5 6 7 8

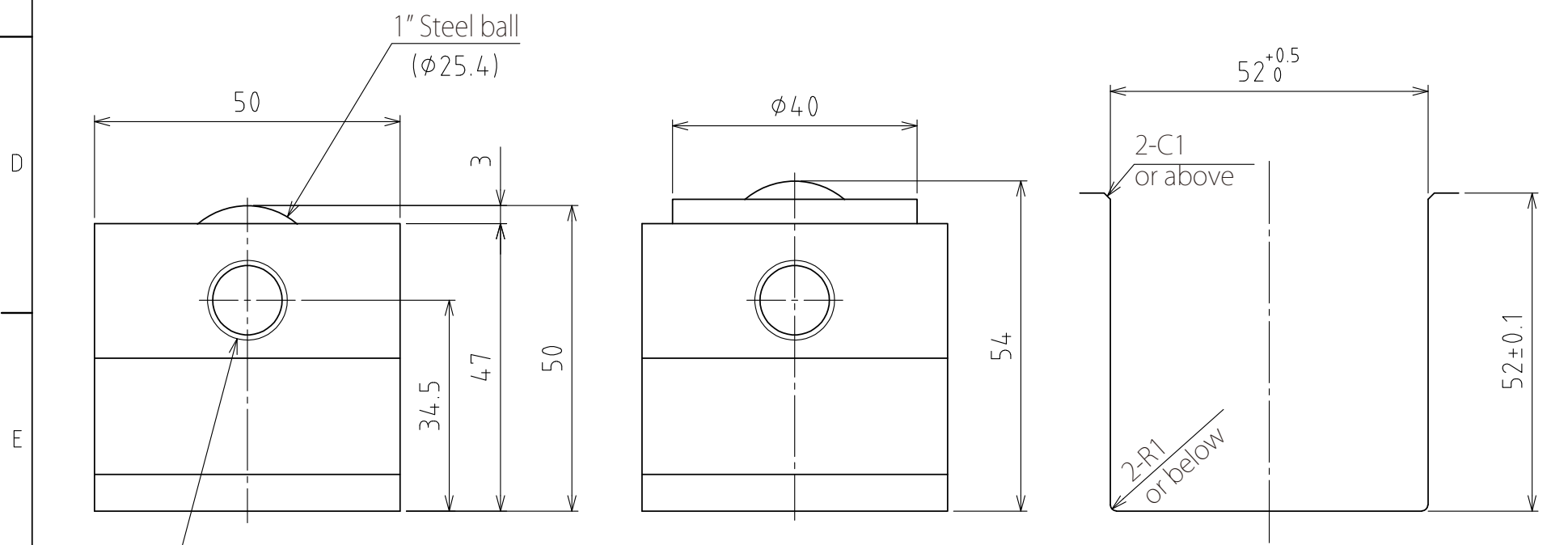

spec

Series	AFU-5050W series	
Freebear	3pcs	
Material	Ball	SUJ2
	Ball seat	SCM415
	Body	Steel
Weight	3.6kg	

Capacity	Air pressure [MPa(kgf/cm ²)]	Load capacity (Unit) [kN(kgf)]	Load capacity (One freebear) [kN(kgf)]
	0.3 (3.1)	2.30(234.0)	0.77(78.0)
	0.4 (4.1)	3.06(312.0)	1.02(104.0)
	0.5 (5.1)	3.84(391.6)	1.28(130.5)
	0.6 (6.1)	4.59(468.0)	1.53(156.0)

Rc1/4

View A

Rising
(stroke 4mm)

Recommended groove dimensions

(Scale 1:1)

設計 DESIGNED BY	古内	2021/07/28	名称 TITLE	Pneumatically Actuated freebear unit
製図 DRAWN BY	古内	2021/07/28		
検図 CHECKED BY	技術部 坂根	承認 APPROVED BY	技術部 花村	AFU-5050W-3
尺度 SCALE	1:3	サイズ SIZE	A3	
第三角法				
			図面番号 DRAWING NO.	変更回数 REV.MARK
			SAU08530-F03	

1 2 3 4 5 6 7 8