

1 2 3 4 5 6 7 8

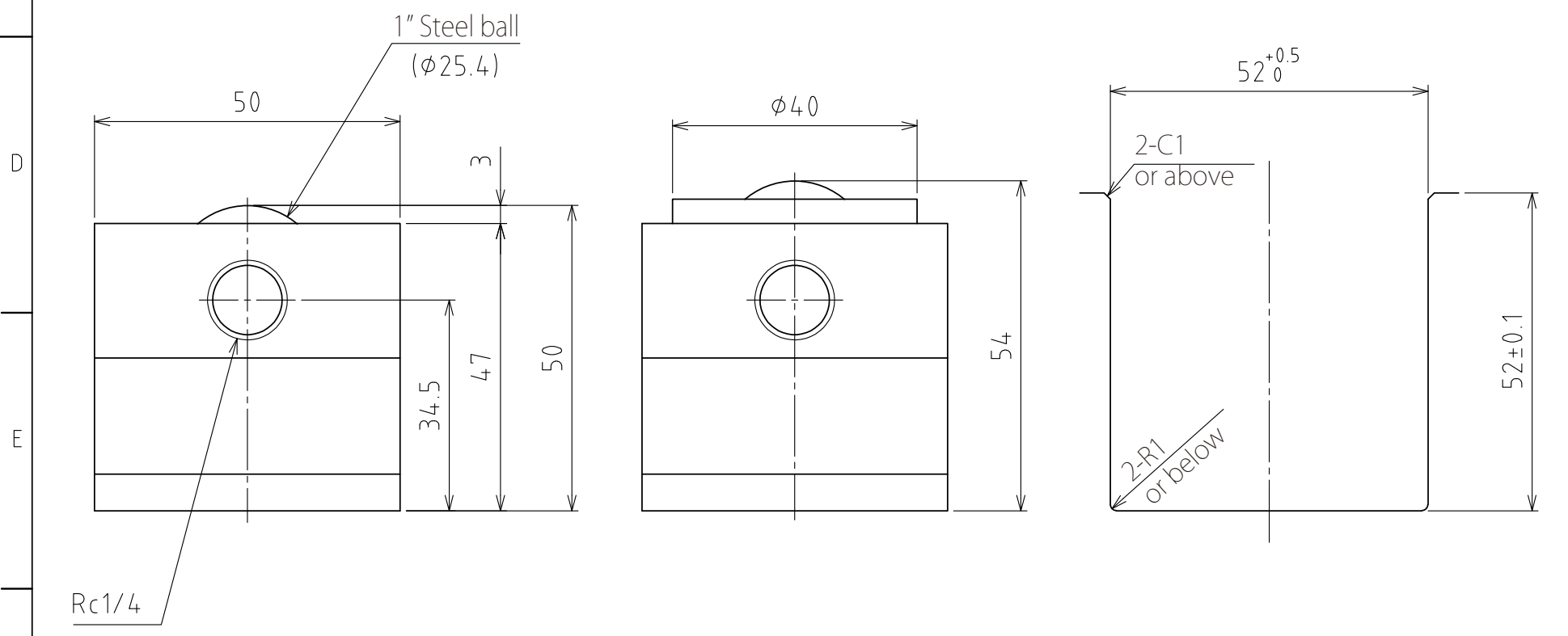

spec

Series	AFU-5050W series	
Freebear	4pcs	
Material	Ball	SUJ2
	Ball seat	SCM415
	Body	Steel
Weight	4.4kg	

Capacity	Air pressure [MPa(kgf/cm ²)]	Load capacity (Unit) [kN(kgf)]	Load capacity (One freebear) [kN(kgf)]
	0.3 (3.1)	3.06(312.1)	0.77(78.0)
0.4 (4.1)	4.08(416.0)	1.02(104.0)	
0.5 (5.1)	5.12(522.1)	1.28(130.5)	
0.6 (6.1)	6.12(624.1)	1.53(156.0)	

Rc1/4

View A

Rising
(stroke 4mm)

(Scale 1:1)

Recommended groove dimensions

設計 DESIGNED BY	古内	2021/07/28	名称 TITLE
製図 DRAWN BY	古内	2021/07/28	
検図 CHECKED BY	技術部 坂根	承認 APPROVED BY	技術部 花村
尺度 SCALE	1:3	サイズ SIZE	A3
第三角法			AFU-5050W-4
			図面番号 DRAWING NO. SAU08531-F03 変更回数 REV.MARK 変更回数

1 2 3 4 5 6 7 8