

1 2 3 4 5 6 7 8

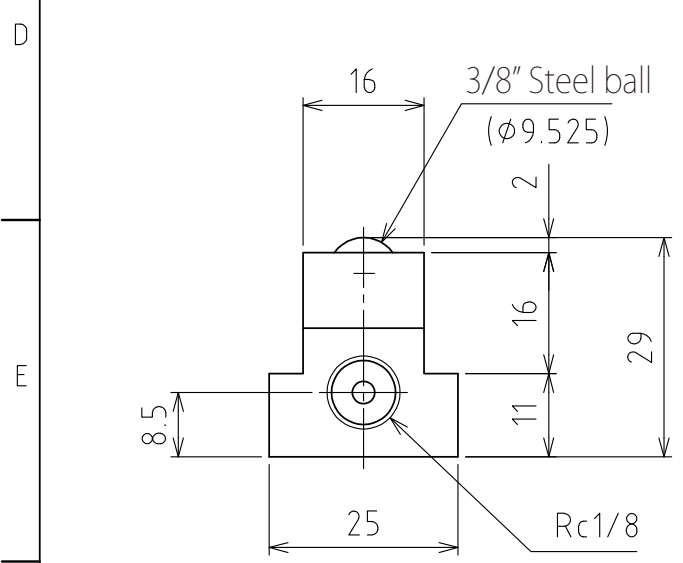

View A

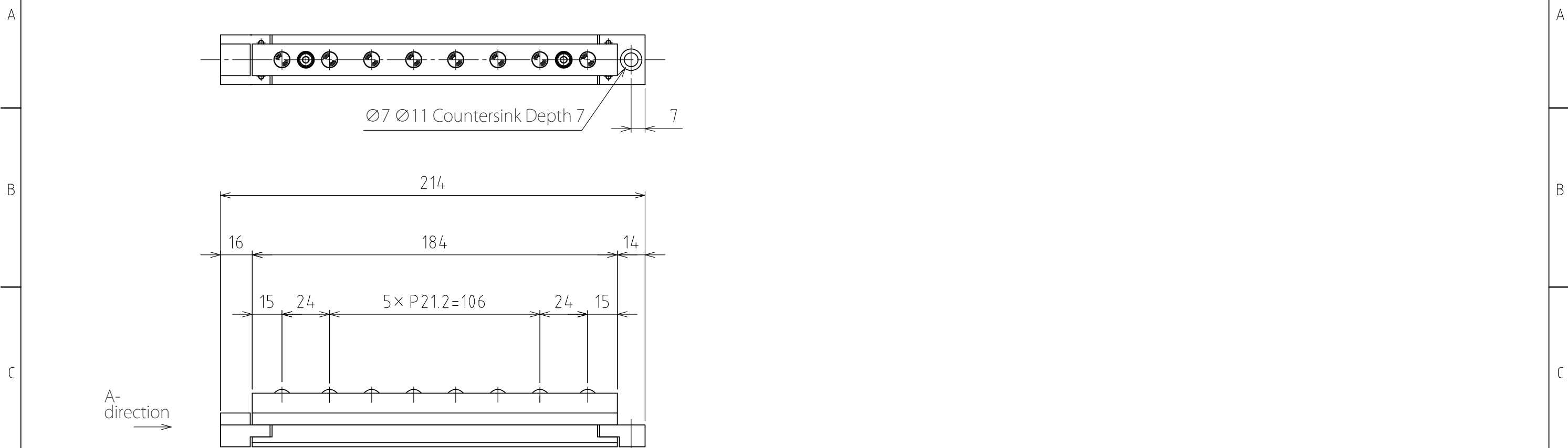
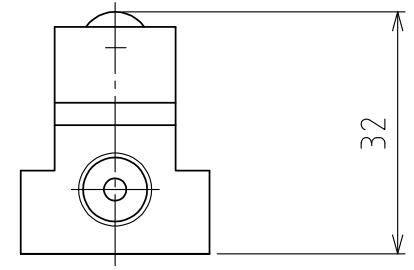

Rising (stroke 3mm)

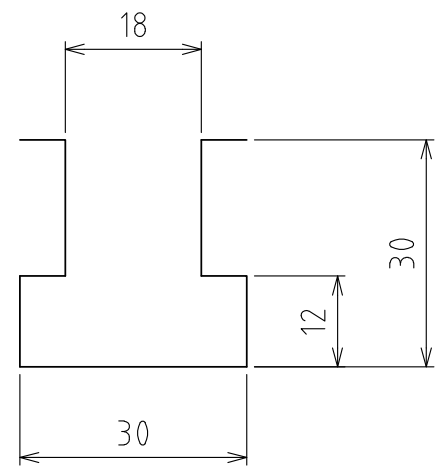

T-groove size

(Scale 1:1)

spec

Series	FAD18T series	
Material	Ball	SUJ2
	Ball seat	SCM415
	Body	Steel
Means to lower the balls	Lowered by means of mold weight or forced exhaust	
Weight	0.8kg	

Capacity	Air pressure [MPa(kgf/cm ²)]	Load capacity (Unit) [kN(kgf)]
	0.3 (3.1)	0.36(36.2)
	0.4 (4.1)	0.47(47.9)
	0.5 (5.1)	0.59(60.2)
	0.6 (6.1)	0.71(72.4)

設計 DESIGNED BY	古内	2021/07/26	名称 TITLE
製図 DRAWN BY	古内	2021/07/26	Pneumatically Actuated freebear unit
検図 CHECKED BY	技術部 坂根 (21.11.29)	承認 APPROVED BY	技術部 花村 (21.11.30)
尺度 SCALE	1:2	サイズ SIZE	A3
第三角法			FAD18T-200
			図面番号 DRAWING NO. SD-01412-F01
			変更回数 REV.MARK

1 2 3 4 5 6 7 8