

1 2 3 4 5 6 7 8

A
B
C
D
E
F

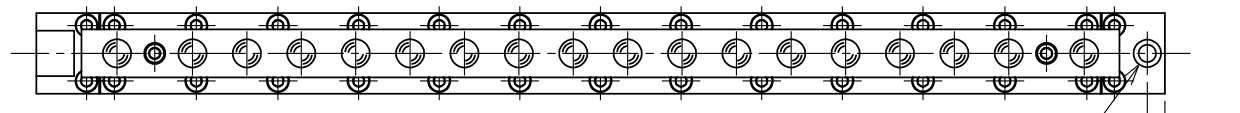

Ø7 Ø11 Countersink Depth 7

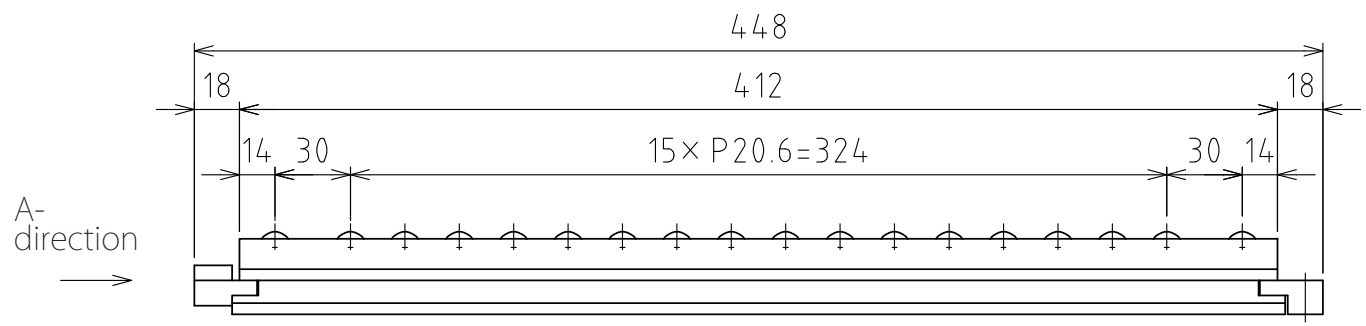

A-direction
→

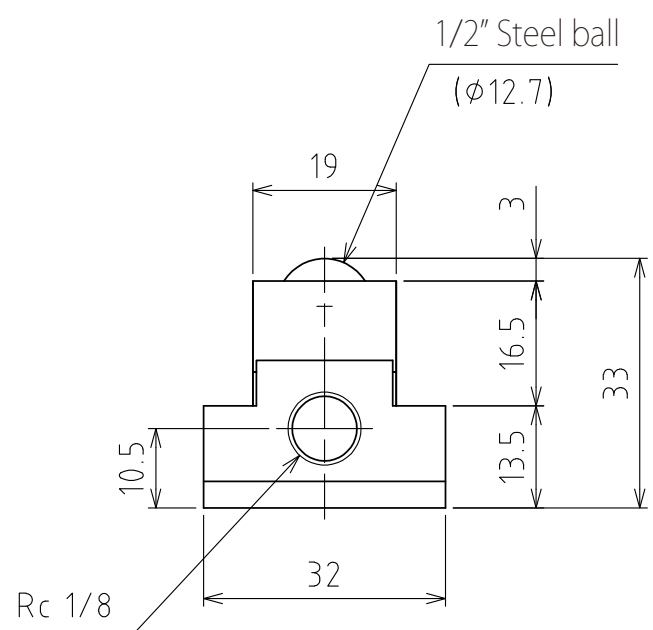

View A

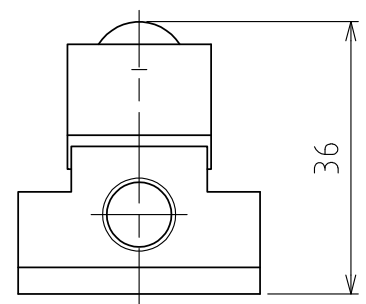

Rising
(stroke 3mm)

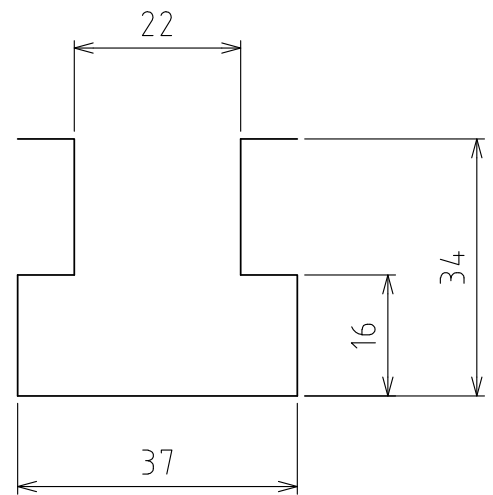

T-groove size

(Scale 1:1)

spec

Series		FAD22T series
Material	Ball	SUJ2
	Ball seat	SCM415
	Body	Steel
Means to lower the balls		Spring return system (lowers by exhausting)
Weight		2.0kg

Capacity	Air pressure [MPa(kgf/cm ²)]	Load capacity (Unit) [kN(kgf)]
	0.3 (3.1)	1.46(148.5)
	0.4 (4.1)	1.73(176.5)
	0.5 (5.1)	2.32(236.7)
	0.6 (6.1)	2.91(297.0)

設計 DESIGNED BY	古内	2021/07/26	名称 TITLE Pneumatically Actuated freebear unit
製図 DRAWN BY	古内	2021/07/26	
検図 CHECKED BY	坂根	21.11.29	FAD22T-450
承認 APPROVED BY	花村	21.11.30	
尺度 SCALE	1:3	サイズ SIZE	A3
第三角法			

	図面番号 DRAWING NO. SD-00330-F01	変更回数 REV.MARK
--	----------------------------------	---------------

1 2 3 4 5 6 7 8