

1 2 3 4 5 6 7 8

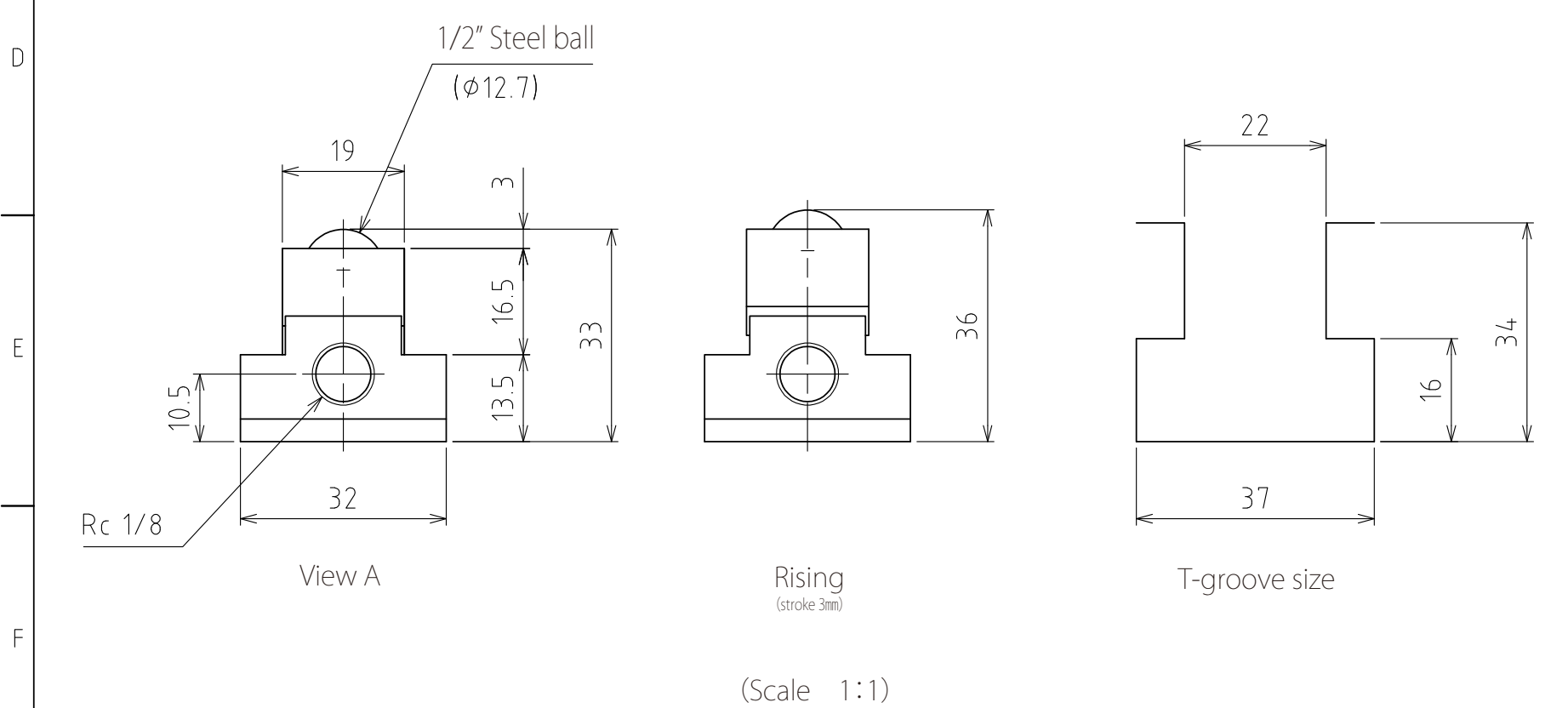
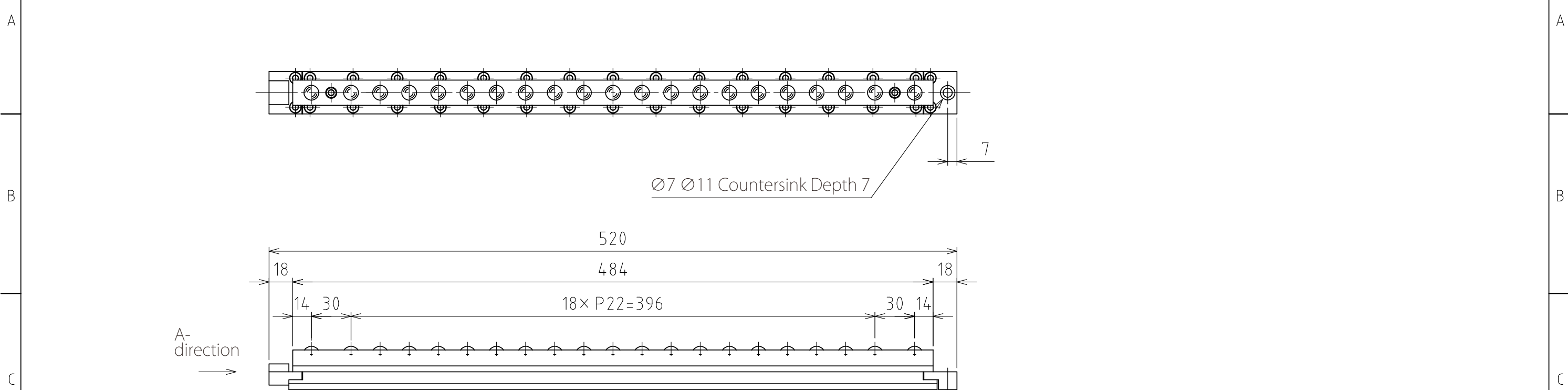

spec

Series	FAD22T series	
Material	Ball	SUJ2
	Ball seat	SCM415
	Body	Steel
Means to lower the balls	Spring return system (lowers by exhausting)	
Weight	2.4kg	

Capacity	Air pressure [MPa(kgf/cm <sup>2</sup> )]	Load capacity (Unit) [kN(kgf)]
	0.3 (3.1)	1.70(173.7)
	0.4 (4.1)	2.02(206.7)
	0.5 (5.1)	2.71(277.0)
	0.6 (6.1)	3.40(347.4)

設計 DESIGNED BY	古内	2021/07/26	名称 TITLE
製図 DRAWN BY	古内	2021/07/26	
検図 CHECKED BY	坂根	21.11.29	FAD22T-520
承認 APPROVED BY	花村	21.11.30	
尺度 SCALE	1:3	サイズ SIZE	A3
第三角法			☉
			図面番号 DRAWING NO. SD-00331-F01
			変更回数 REV.MARK

1 2 3 4 5 6 7 8